

SEQUE DESIGNS

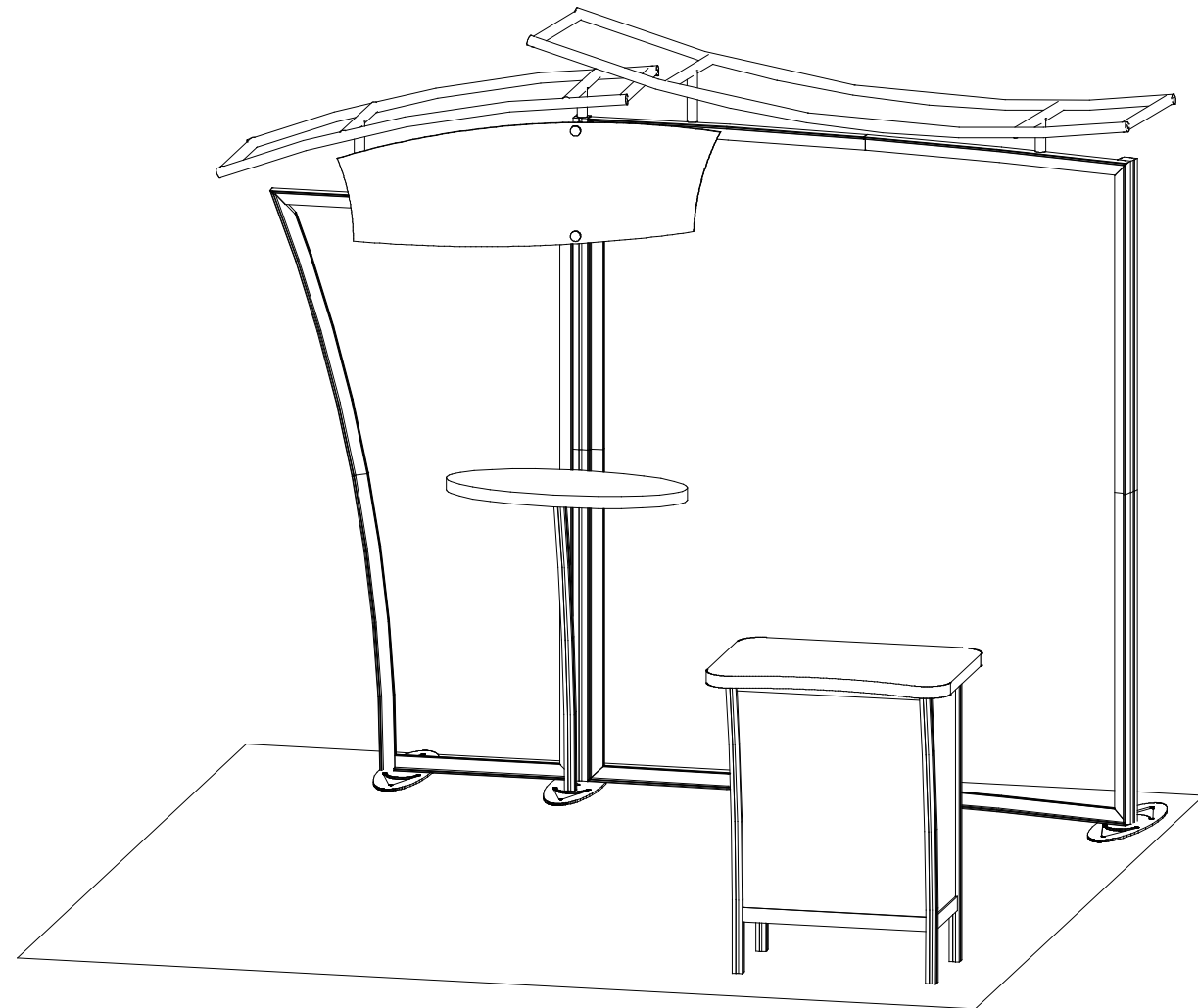
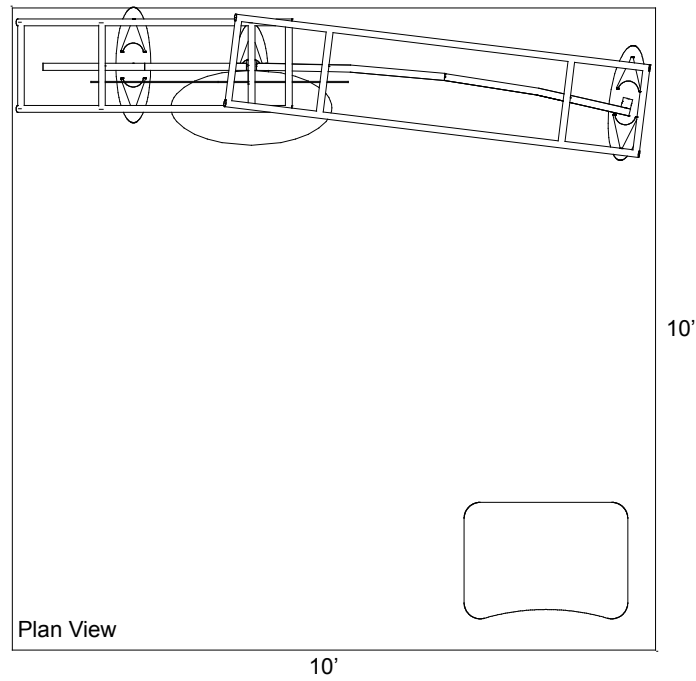

WHEN DISASSEMBLING ALUMINUM EXTRUSION, TIGHTEN ALL SETSCREWS AND LOCKS TO PREVENT LOSS DURING SHIPPING

visionary™ DESIGNS

Using Your Setup Instructions

The Visionary Designs Setup Instructions are created specifically for your configuration. They are laid out sequentially, including an exploded view of the entire display, and then a logical series of detailed steps to assemble the main structure and components. We encourage you to study the instructions **before** attempting to assemble your exhibit.

Each page reminds you to tighten the setscrews after disassembling your exhibit to prevent loss of the locks and setscrews (see below in RED). This is VERY IMPORTANT.

Cleaning and Packing Your Display

- 1) Use care when cleaning aluminum extrusion or acrylic inserts. Use only non-abrasive cleaners.
- 2) When cleaning laminate inserts or countertops, use mild cleansers and a soft material such as cotton.
- 3) Keep all display components away from extreme heat and long exposure to sunlight to avoid warping and fading.
- 4) Retain all packing material. It will make re-packing much easier and will reduce the likelihood of shipping damage.



The Tool

Most Visionary Designs exhibits can be assembled with the supplied Hex Key Tool. Occasionally, a flat head screwdriver may be required.



Typical Connection

Most horizontal extrusion connections have a patented expandable lock. This lock inserts into the groove of an opposing extrusion. Tightening the lock with the Hex Key Tool expands the lock and creates a strong positive connection.



Typical Connection (cont'd)

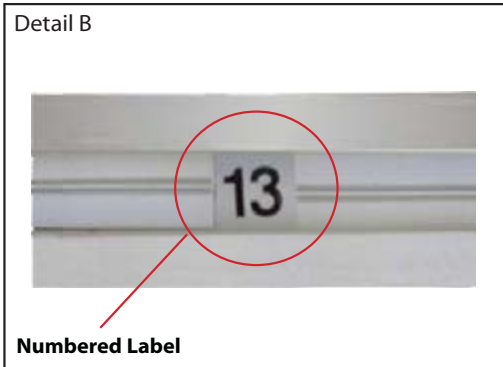

Numbered Label

Each extrusion contains a numbered label which corresponds with setup instructions. The label is located within a groove of the extrusion (when possible). With Visionary Designs the labels contain Black numbers unless otherwise specified.



Horizontal Inline Connection (remove only one setscrew)

Remove only (1) setscrew when disassembling. Replace setscrew in extrusion after assembling it. Before packing, replace setscrew in extrusion to avoid losing it.

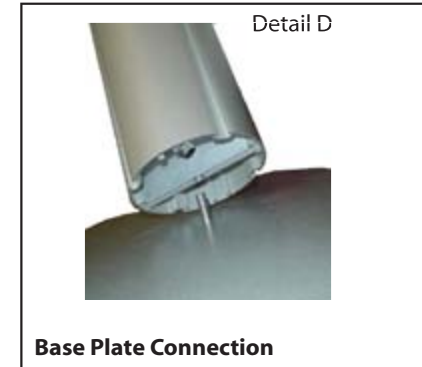

Base Plate Connection

Attach base plate to round or square vertical extrusion using the bolt provided. Be careful not to strip the threads.

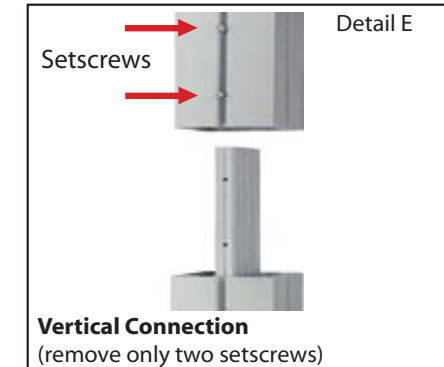

Vertical Connection (remove only two setscrews)

When vertical extrusions are packed in portable cases rather than crates or tubs, they must be broken down into smaller sections which then require assembly.

Remove only (2) setscrews when disassembling. Replace setscrews in extrusion after assembling it. Before packing, replace setscrews in extrusion to avoid losing them.

WHEN DISASSEMBLING ALUMINUM EXTRUSION, TIGHTEN ALL SETSCREWS AND LOCKS TO PREVENT LOSS DURING SHIPPING

SEG Graphic: To Ensure Proper Fit

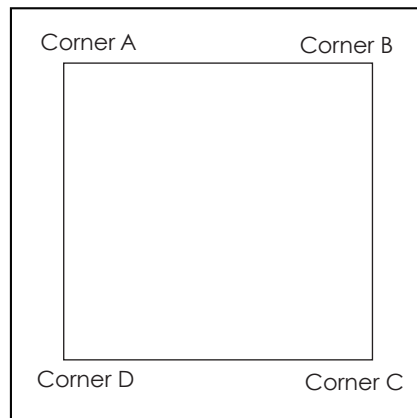

It is important to first insert graphic into each alternater corner then to the sides of the frame.
If this is not done, graphic will not fit into the frame correctly.

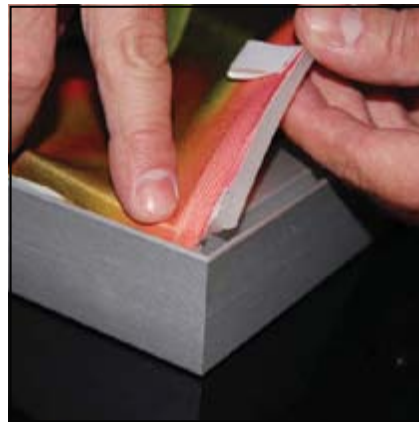

Step 1
Insert corner A.
Turn edge of graphic so silicon welt is perpendicular to face of graphic. Insert narrow side of welt with fabric to outside into the channel. Repeat for other side of this corner.



Step 2
Repeat Step 1 for opposite corner C, then insert corner B, followed by corner D, to complete the installation of the corners.



Step 3
Once all corners are inserted, press one silicon edge into channel from corners and work toward the center. Make sure welt is fully inserted into channel. Continue until all sides are done. Smooth out edges of graphic.

Graphic Removal

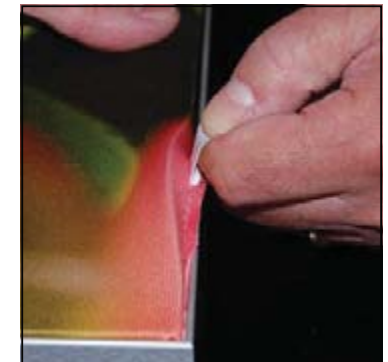

To remove the graphic from the frame, locate the fabric pull tab. Gently pull up on the tab to remove the fabric.

WHEN DISASSEMBLING ALUMINUM EXTRUSION, TIGHTEN ALL SETSCREWS AND LOCKS TO PREVENT LOSS DURING SHIPPING

866.652.2100

Item	Qty.	Description
1/1a	2/1	Base Plate
2	1	41.5"h Vertical Extrusion
3	1	41.5"h Vertical Extrusion
4	1	41.5"h Vertical Extrusion
4a	1	Flange Plate
5	1	10.107"w Horizontal Extrusion
6	1	41.5"h Vertical Extrusion
7	1	41.5"h Vertical Extrusion

Steps:

- 1) Attach lower extrusions to base plate.
- 2) Attach upper verticals to lower verticals as shown.
- 3) Connect horizontal [5] between verticals [2 and 4].
- 4) Attach flange plate atop vertical [4] as shown.

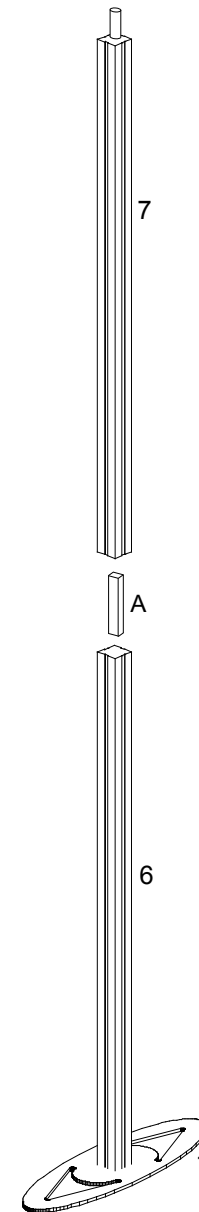
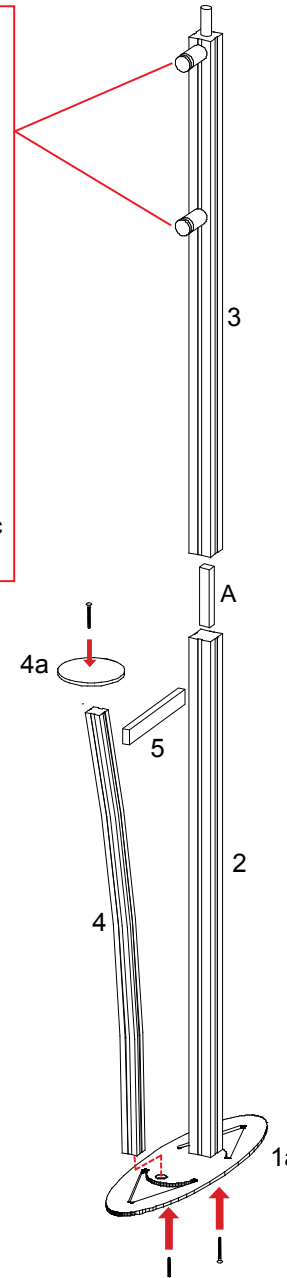
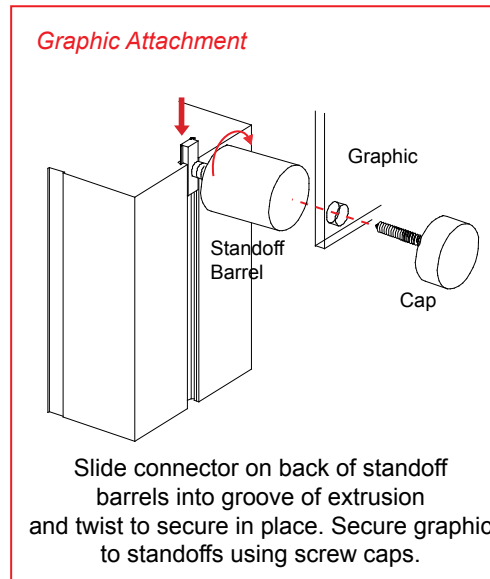

WHEN DISASSEMBLING ALUMINUM EXTRUSION, TIGHTEN ALL SETSCREWS AND LOCKS TO PREVENT LOSS DURING SHIPPING

866.652.2100

Item	Qty.	Description
8	1	34.92" Curved SEG Extrusion
9	1	34.92" Curved SEG Extrusion
10	1	19"w SEG Extrusion
11	1	19"w SEG Extrusion
12	1	35.9385"h SEG Extrusion
13	1	35.9385"h SEG Extrusion
14	1	24.242"w SEG Extrusion
15	1	41.5"h SEG Extrusion
16	1	41.5"h SEG Extrusion
17	1	32.263"w Curved SEG Extrusion
18	1	32.263"w Curved SEG Extrusion
19	1	41.5"h SEG Extrusion
20	1	41.5"h SEG Extrusion
21	1	32.263"w Curved SEG Extrusion
22	1	32.263"w Curved SEG Extrusion

Steps:

- 1) Assemble SEG extrusions together [8 to 14].
- 2) Attach base plate [1] to bottom of assembled frame [14].
- 3) Lock verticals [12 and 13] to left side of verticals [2 and 3]
- 4) Assemble SEG extrusions together [15 to 22].
- 5) Secure right side of assembled frame to verticals [6 and 7] and lock left side of assembled frame to right side of verticals [2 and 3].

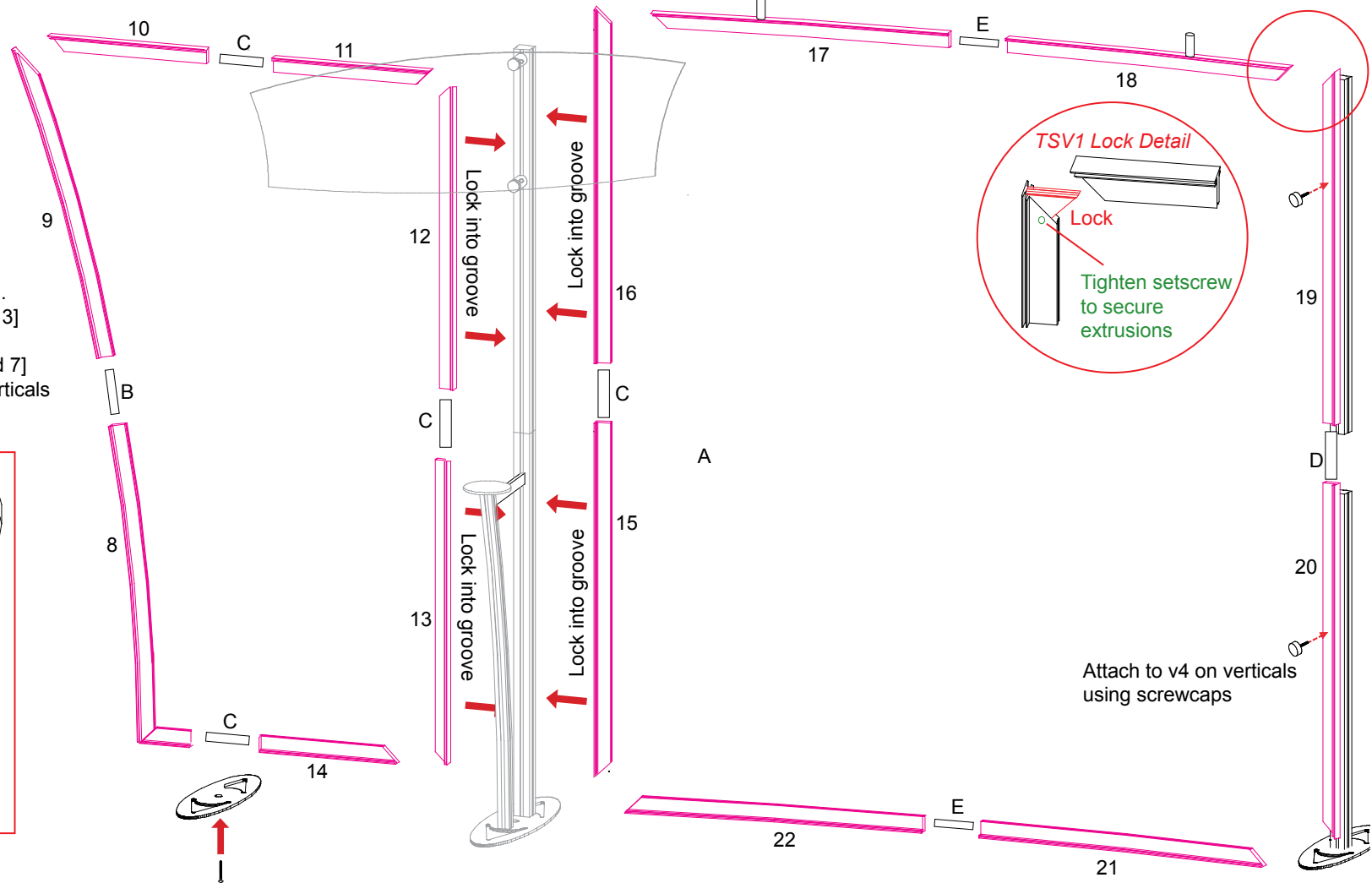
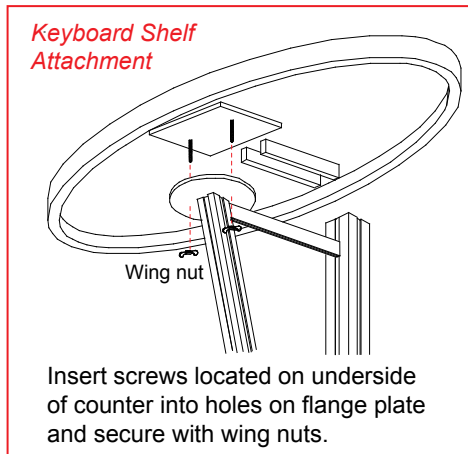

WHEN DISASSEMBLING ALUMINUM EXTRUSION, TIGHTEN ALL SETSCREWS AND LOCKS TO PREVENT LOSS DURING SHIPPING

AERO

Using Your Setup Instructions

The Aero Overhead Sign Setup Instructions are created specifically for your configuration. They include an exploded view of the frame which is sequentially numbered. We encourage you to study the instructions before attempting to assemble your exhibit.

Connections are kept very simple: no tools. Everything assembles with push-button connectors and pre-connected horizontal sections.

Cleaning and Packing Your Display

- 1) Use care when cleaning aluminum extrusion or acrylic inserts. Use only non-abrasive cleaners.
- 2) Retain all packing material. It will make re-packing much easier and will reduce the likelihood of shipping damage.

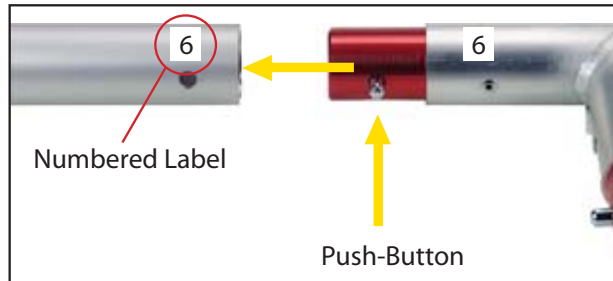

Connections are made by holding the button down and sliding the red tube into opposing tube until the connection is made. To disassemble push button and pull or twist extrusions apart.

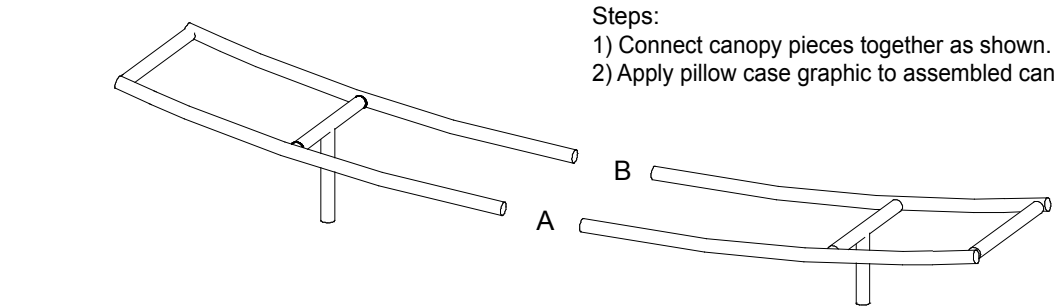
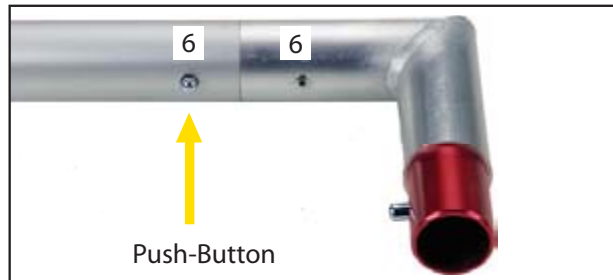

Steps:

- 1) Connect canopy pieces together as shown.
- 2) Apply pillow case graphic to assembled canopy

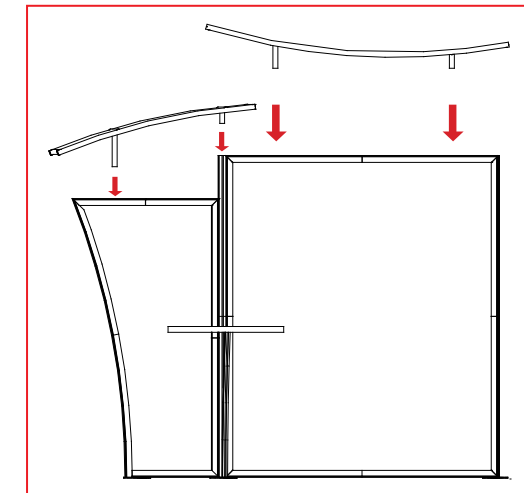
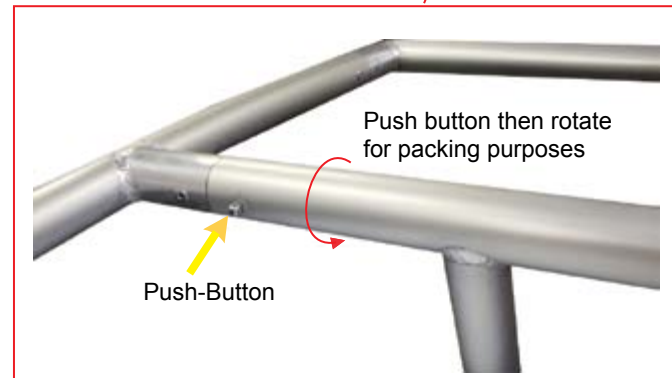
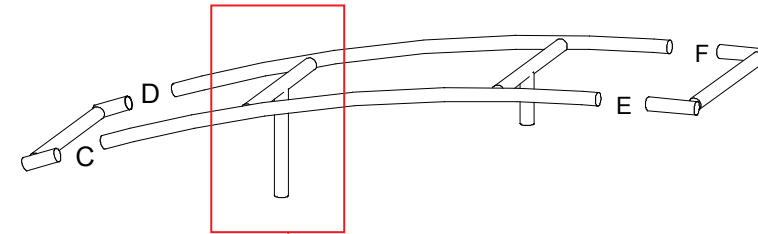

WHEN DISASSEMBLING ALUMINUM EXTRUSION, TIGHTEN ALL SETSCREWS AND LOCKS TO PREVENT LOSS DURING SHIPPING

866.652.2100

Item	Qty.	Description
23	1	38.2854" Curved Vertical Extrusion
24	1	38"h Vertical Extrusion
25	1	38"h Vertical Extrusion
26	1	38.2854" Curved Vertical Extrusion
27	1	11"w Horizontal Extrusion
28	1	14.567"w Horizontal Extrusion
29	1	11"w Horizontal Extrusion
30	1	14.567"w Horizontal Extrusion
31	2	23"w Horizontal Extrusion
32	1	23"w Horizontal Extrusion
33	1	23.505"w Horizontal Extrusion

Steps:

- 1) Connect horizontal [31, 32 and 33] between side assemblies as shown.
- 2) Set floor atop lip of extrusions [31, 32 and 33].
- 3) Place counter top atop assembled pedestal.

Extrusions 27, 29 and 31 have a lip for the floor to rest upon.

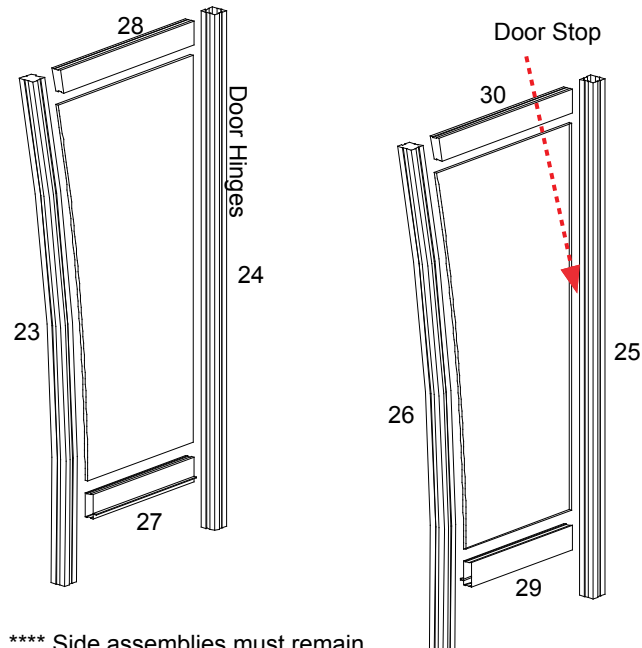

**** Side assemblies must remain assembled when shipping in jugged cases

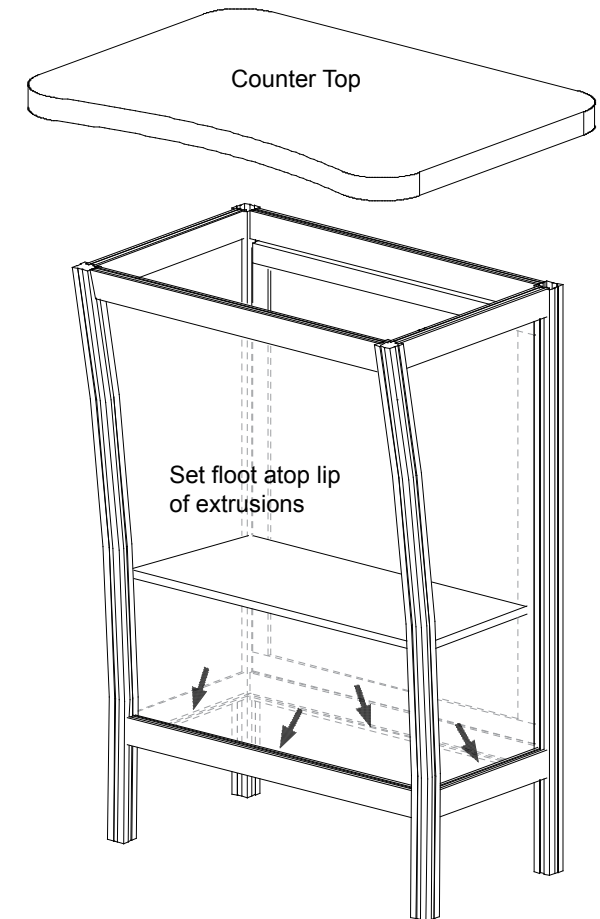
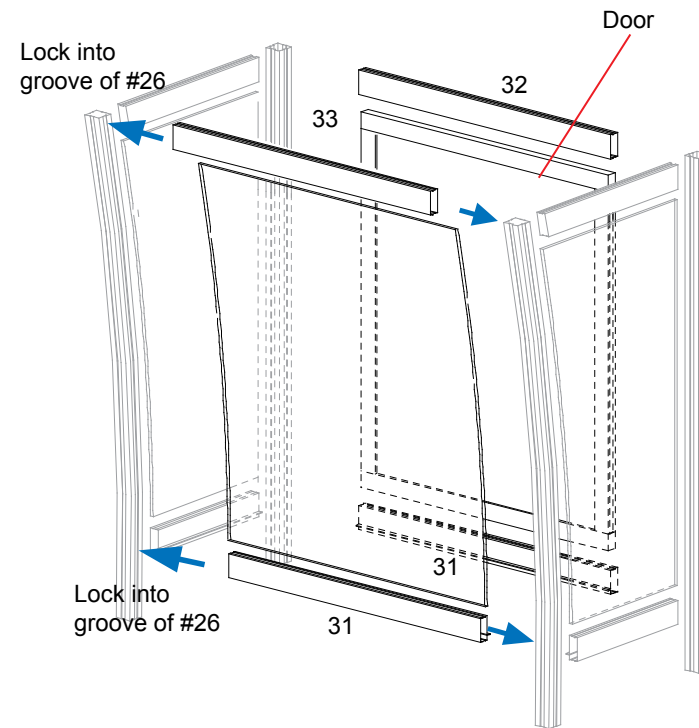

WHEN DISASSEMBLING ALUMINUM EXTRUSION, TIGHTEN ALL SETSCREWS AND LOCKS TO PREVENT LOSS DURING SHIPPING

Top View of each Level

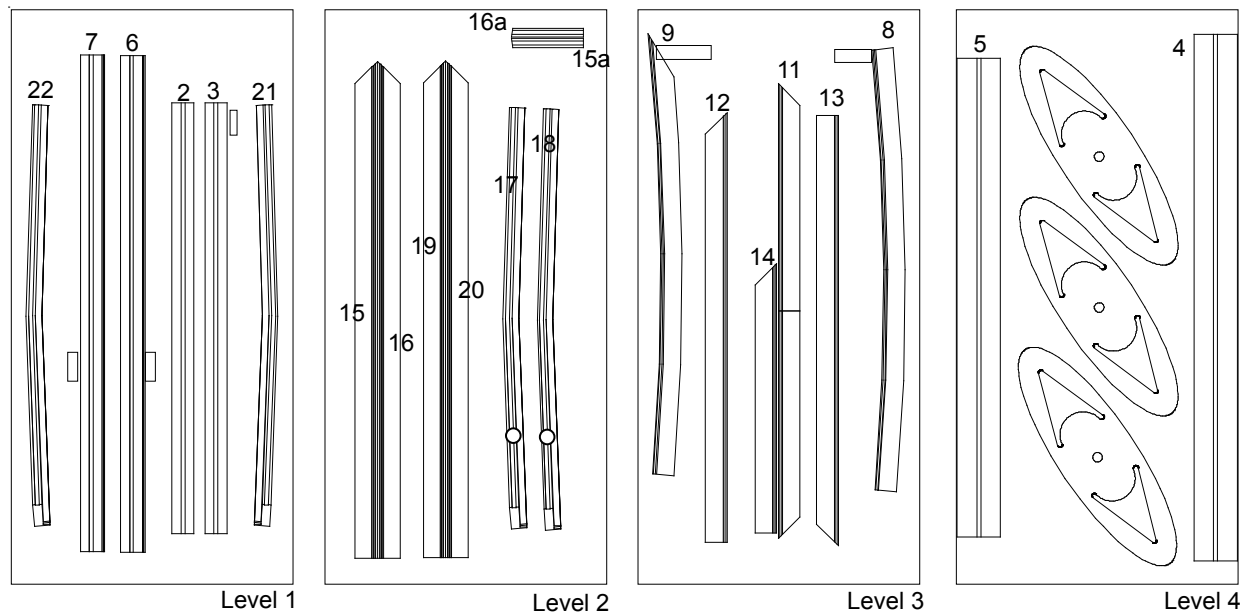

WHEN DISASSEMBLING ALUMINUM EXTRUSION, TIGHTEN ALL SETSCREWS AND LOCKS TO PREVENT LOSS DURING SHIPPING

866.652.2100

Top View of each Level

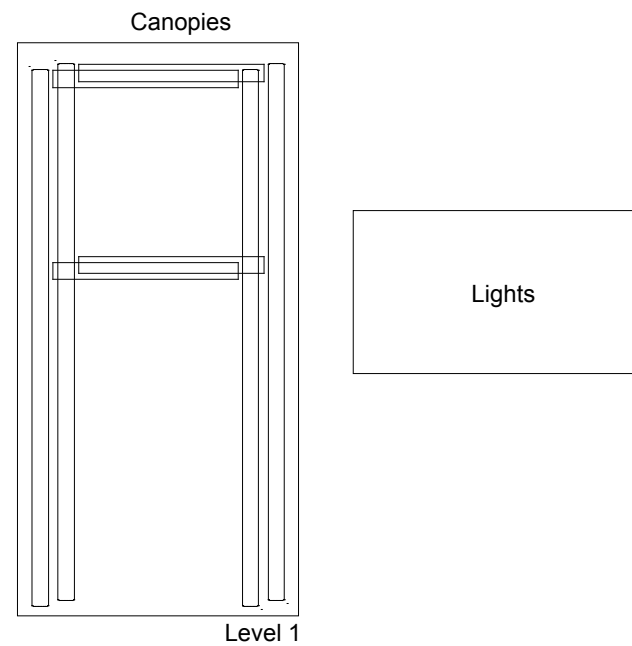

WHEN DISASSEMBLING ALUMINUM EXTRUSION, TIGHTEN ALL SETSCREWS AND LOCKS TO PREVENT LOSS DURING SHIPPING

Top View of each Level

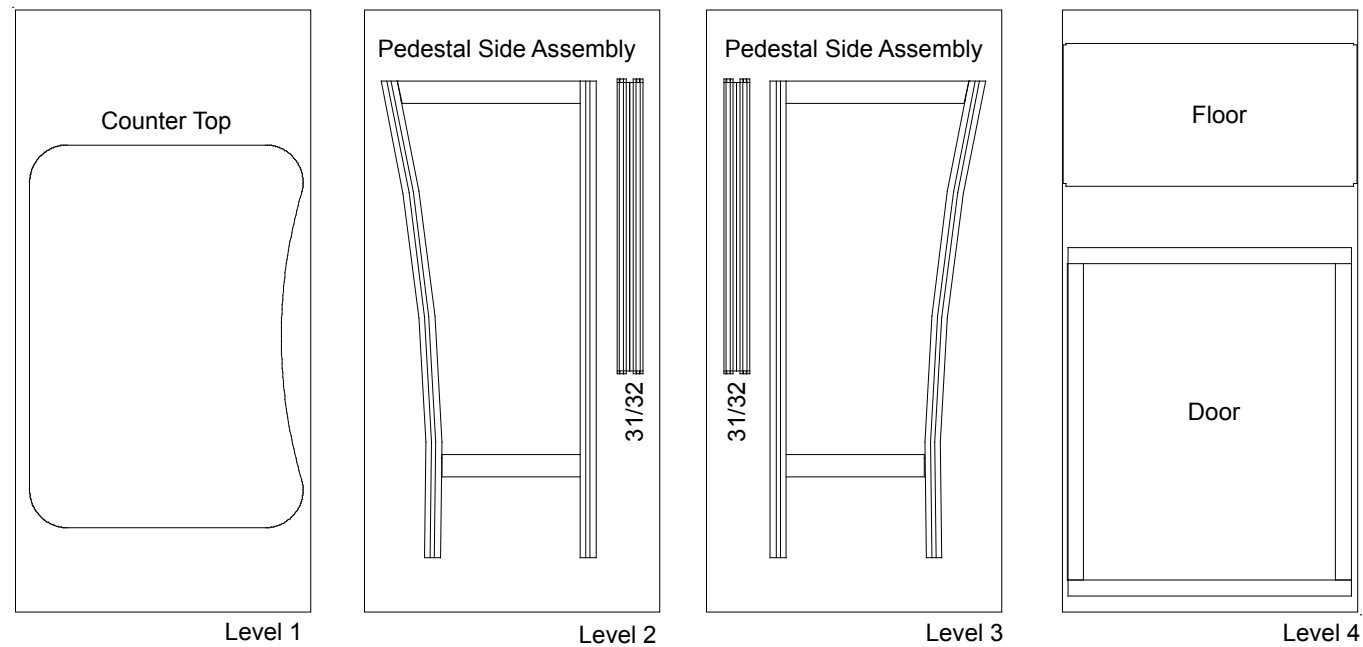

WHEN DISASSEMBLING ALUMINUM EXTRUSION, TIGHTEN ALL SETSCREWS AND LOCKS TO PREVENT LOSS DURING SHIPPING